

A.C. ELECTRO HYDRAULIC THRUSTER (EMT-6/ ST 13225)

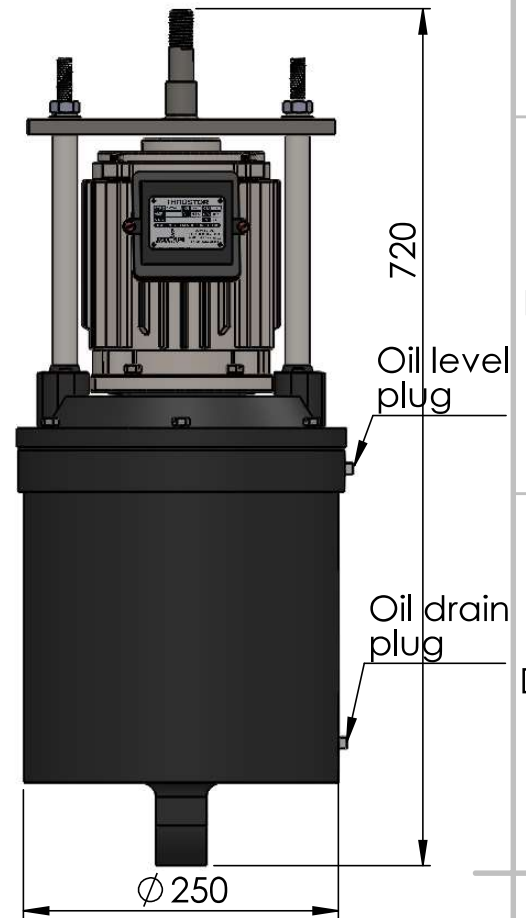
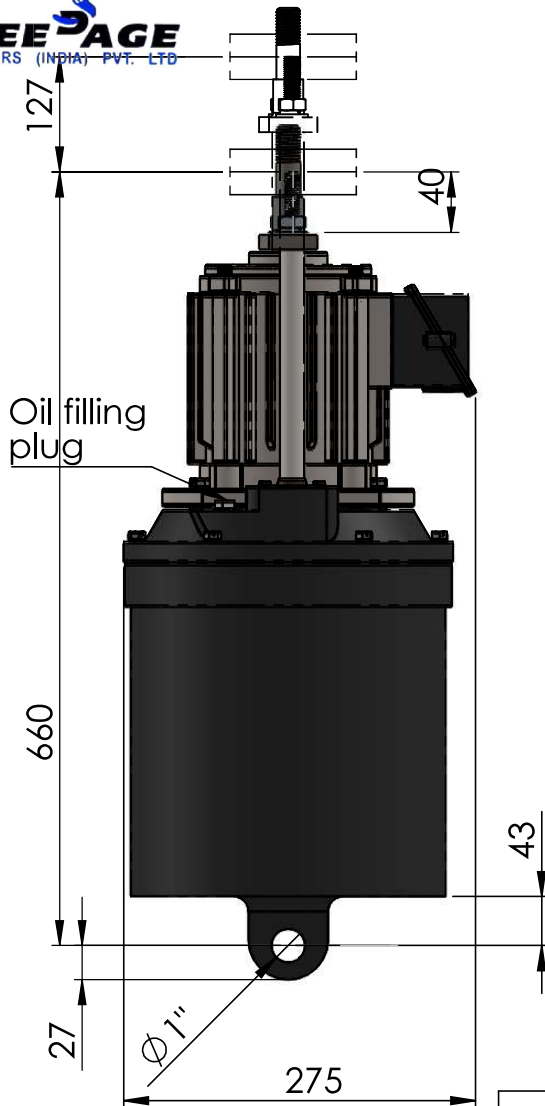

Type	EMT-6/ ST 13225
Thrust Capacity (Kg)	225
Thrust stroke (mm)	127
Input Watts	420
Input Supply*	415V/ 3 Ø / 50Hz
Oil Capacity (Ltr.)**	9
Weight (Kg)	50

Notes:

1. Operating position of thruster must be within 10° of the vertical.
2. Supply leads must be flexible and allow thruster to pivot.

- * Thruster can also be supply with differant voltage and frequency as per customer requirments.
- ** Oil should be use Transformer Oil BS 148.

UNLESS OTHERWISE SPECIFIED:
DIMENSIONS ARE IN MILLIMETERS
SURFACE FINISH:
TOLERANCES:
LINEAR:
ANGULAR:

FINISH:

DEBURR AND
BREAK SHARP
EDGES

DO NOT SCALE DRAWING

REVISION

Speedage Engineers (India) Pvt. Ltd.

NAME	SIGNATURE	DATE	contact
DRAWN Er. Himanshu Tiwari			
CHKD			
APPVD J.A. Raichandani		9810173991	
MFG			

TITLE:
EMT-6/ ST 13225

Q.A
THIS DRAWING IS THE PROPERTY OF **SPEEDAGE ENGINEERS (INDIA) PVT. LTD.** & MUST NEITHER BE COPIED NOR BE MADE KNOWN TO ANY OTHER PARTY WITHOUT THEIR PRIOR WRITTEN CONSENT.

MATERIAL:

DWG NO.

SAE/DWG/TH225/01

A4

WEIGHT:

SCALE:1:10

SHEET 1 OF 1