

4

3

2

1

A.C. ELECTRO HYDRAULIC THRUSTER (EMT-5/ ST 8115)

SPEEDAGE
ENGINEERS (INDIA) PVT. LTD.

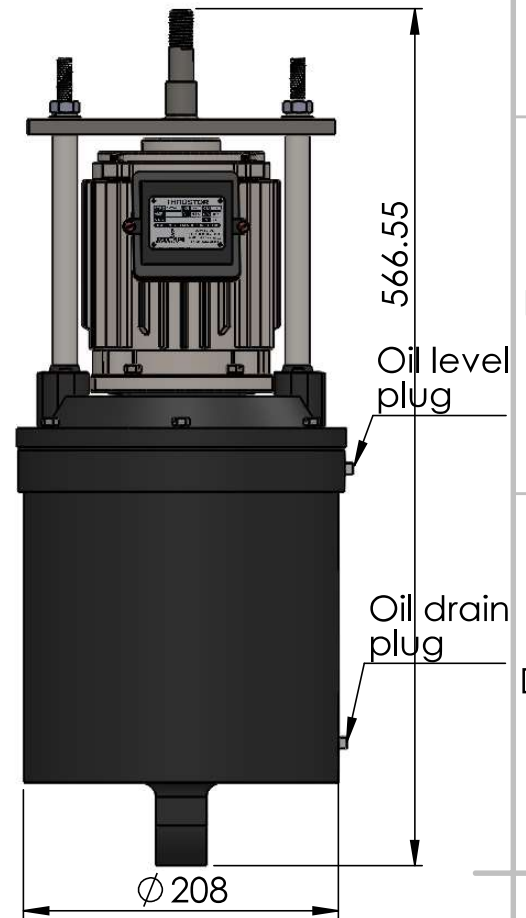
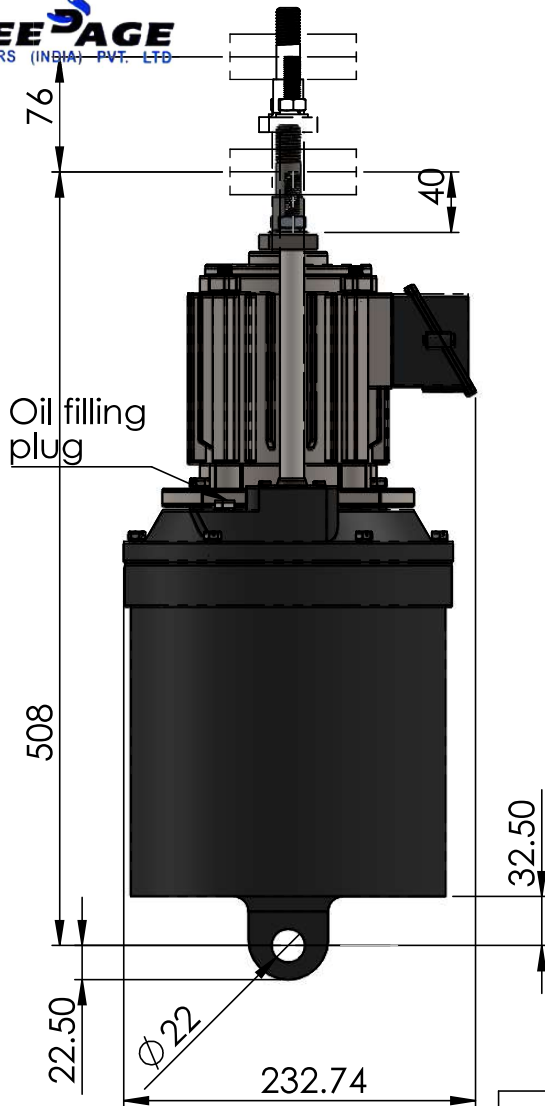

Type	EMT-5/ ST 8115
Thrust Capacity (Kg)	114
Thrust stroke (mm)	76
Input Watts	250
Input Supply*	415V/ 3 ϕ / 50Hz
Oil Capacity (Ltr.)**	4.5
Weight (Kg)	35

Notes:

- Operating position of thruster must be within 10° of the vertical.
- Supply leads must be flexible and allow thruster to pivot.

- * Thruster can also be supply with differant voltage and frequency as per customer requirments.
- ** Oil should be use Transformer Oil BS 148.

UNLESS OTHERWISE SPECIFIED:
DIMENSIONS ARE IN MILLIMETERS
SURFACE FINISH:
TOLERANCES:
LINEAR:
ANGULAR:

FINISH:

DEBURR AND
BREAK SHARP
EDGES

DO NOT SCALE DRAWING

REVISION

Speedage Engineers (India) Pvt. Ltd.

TITLE:

EMT-5/ ST 8115

NAME	SIGNATURE	DATE	Contact
Er. Himanshu Tiwari			
J.A. Raichandani		9810173991	

DRAWN Er. Himanshu Tiwari

CHKD

APPVD J.A. Raichandani

MFG

Q.A

MATERIAL:

DWG NO.

SAE/DWG/TH114/01

A4

THIS DRAWING IS THE PROPERTY OF **SPEEDAGE ENGINEERS (INDIA) PVT. LTD.** & MUST NEITHER BE COPIED NOR BE MADE KNOWN TO ANY OTHER PARTY WITHOUT THEIR PRIOR WRITTEN CONSENT.

WEIGHT:

SCALE:1:10

SHEET 1 OF 1

4

3

2

1