

CWLS LIMIT SWITCH FOR HOISTING

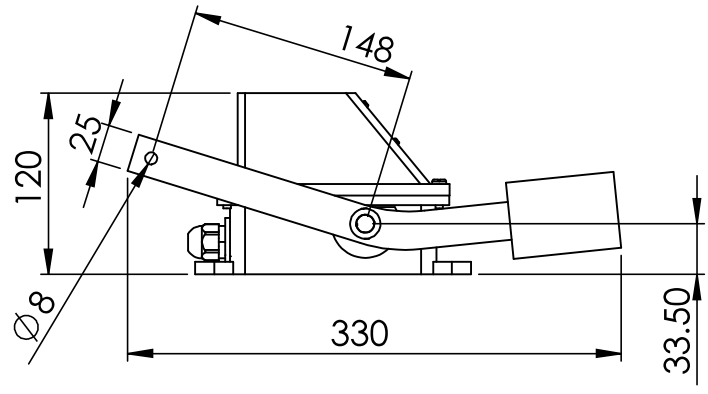
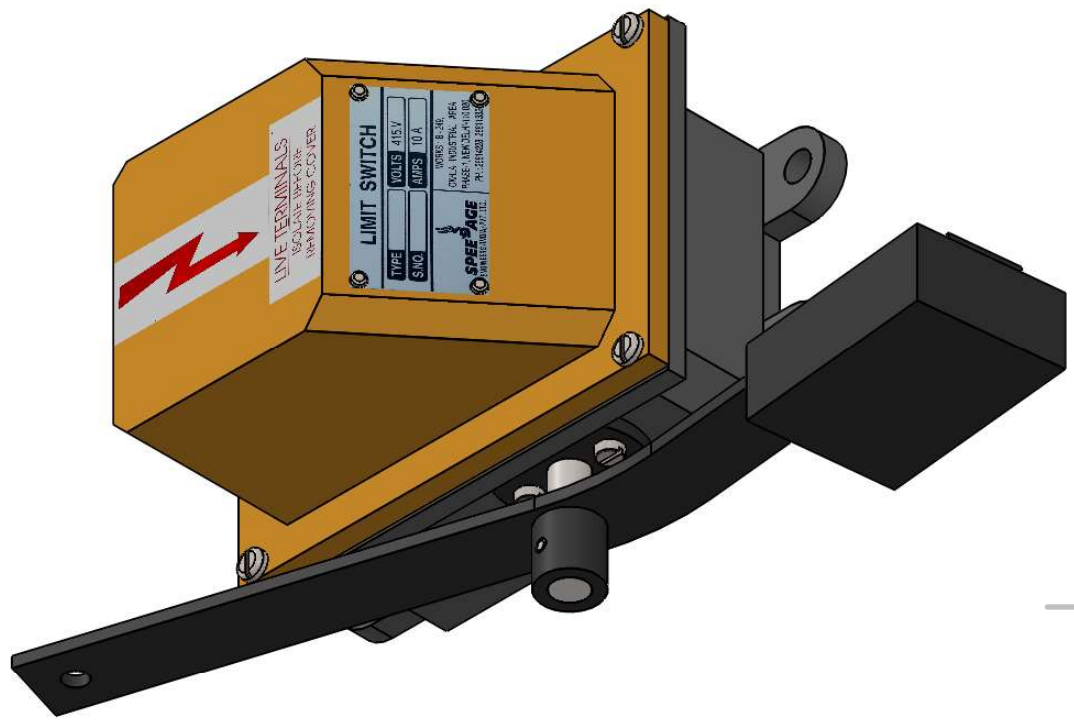
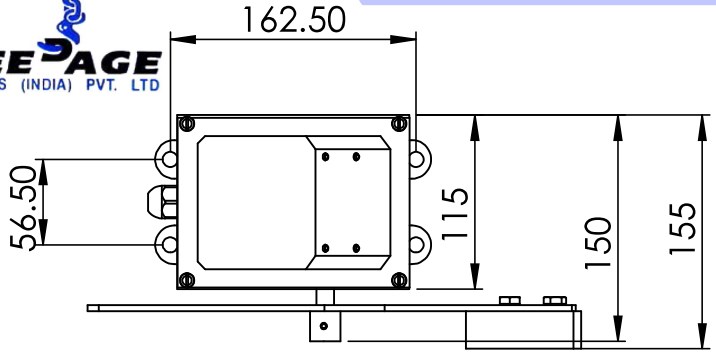

UNLESS OTHERWISE SPECIFIED:
DIMENSIONS ARE IN MILLIMETERS
SURFACE FINISH:
TOLERANCES:
LINEAR:
ANGULAR:

FINISH:

DEBURR AND
BREAK SHARP
EDGES

DO NOT SCALE DRAWING

REVISION

Speedage Engineers (India) Pvt. Ltd.

NAME	SIGNATURE	DATE	CONTACT
DRAWN Himanshu Tiwari			
CHKD			
APPV'D J.A. Raichandani			9810173991
MFG			

TITLE: Counter Weight Limit Switch
415V, 10A
Degree of protection: IP55
No. of contacts:- 2NC/2NO/1NC+1NO

Q.A
THIS DRAWING IS THE PROPERTY OF **SPEEDAGE ENGINEERS (INDIA) PVT. LTD.** & MUST NEITHER BE COPIED NOR BE MADE KNOWN TO ANY OTHER PARTY WITHOUT THEIR PRIOR WRITTEN CONSENT.

MATERIAL:
Housing:- Cast Aluminium

DWG NO.
SAE/DWG/CWLS/01

A4

WEIGHT:

SCALE: 1:5

SHEET 1 OF 1