

4

3

2

1



PENDANT PUSH BUTTON STATION SPBS6EL

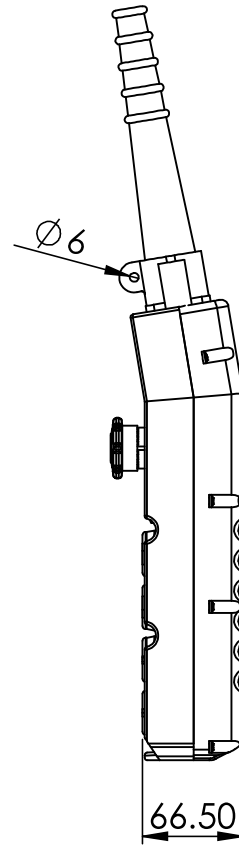
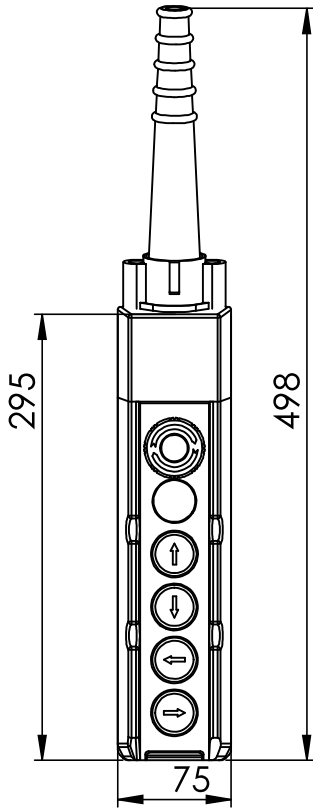
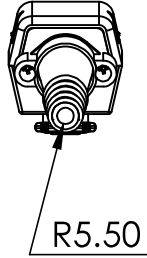

UNLESS OTHERWISE SPECIFIED:
DIMENSIONS ARE IN MILLIMETERS
SURFACE FINISH:
TOLERANCES:
LINEAR:
ANGULAR:

FINISH:

DEBURR AND
BREAK SHARP
EDGES

DO NOT SCALE DRAWING

REVISION

Speedage Engineers (India) Pvt. Ltd.

	NAME	SIGNATURE	DATE	CONTACT
DRAWN	Er. Himanshu Tiwari			
CHKD				
APPVD	J.A. Raichandani			9810173991
MFG				

TITLE:
Pendant push button
415V,10A
Degree of protection: IP65
No. of contacts:- 6

THIS DRAWING IS THE PROPERTY OF **SPEEDAGE ENGINEERS (INDIA) PVT. LTD.** & MUST NEITHER BE COPIED NOR BE MADE KNOWN TO ANY OTHER PARTY WITHOUT THEIR PRIOR WRITTEN CONSENT.

MATERIAL:
Enclosure:- ABS

DWG NO. **SAE/DWG/SPBS6EL/01**

A4

WEIGHT:

SCALE:1:5

SHEET 1 OF 1

4

3

2

1